

TM 9-1581

U113
12
TM
1941

U.S. Dept. of Army

WAR DEPARTMENT

TECHNICAL MANUAL

ORDNANCE MAINTENANCE

TELESCOPIC SIGHTS M1 AND T3

October 4, 1941

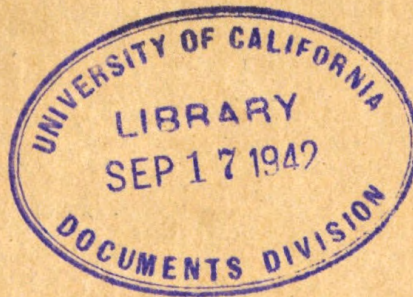

Doc will
just
wash me

U113
12

TM 9:1581
1941

TECHNICAL MANUAL }
No. 9-1581



WAR DEPARTMENT,
WASHINGTON, October 4, 1941.

ORDNANCE MAINTENANCE
TELESCOPIC SIGHTS M1 AND T3

Prepared under direction of the
Chief of Ordnance

| | Paragraph |
|------------------------------------|------------|
| General | 1 |
| Description and operation | 2 |
| Inspection | 3 |
| Maintenance and repair | 4 |
| Care and preservation | 5 |
| APPENDIX. List of references | Page 12 |

1. **General.**—*a. Purpose.*—This manual is published primarily for the information and guidance of ordnance maintenance personnel.

b. Scope.—This manual supplements the Technical Manuals which are prepared for the using arm. It contains general descriptive matter and detailed instructions for maintenance and repair of the sight by ordnance personnel. Figures which accompany the text show the placement and method of fastening of each of the component parts of the sight.

c. References.—All Standard Nomenclature Lists and other publications pertaining to the telescopic sight are listed in the appendix.

2. **Description and operation.**—*a. Description.*—(1) The telescopic sight M1 is the standard telescopic sight for use with the Browning machine gun, caliber .50, HB, M2, ground.

(2) A limited procurement telescopic sight, designated telescopic sight T3, has been manufactured in quantity and is available for use with this machine gun. Except for range dial graduations and slight difference in size, the telescopic sight T3 is similar to the telescopic sight M1. The following description, while intended primarily for the telescopic sight M1, is applicable to the telescopic sight T3 as well, with the exceptions noted.

(3) The telescopic sight has a magnifying power of 3.25X with a field of view of 12°. The reticle pattern (fig. 6) consists of a centrally located aiming post flanked on both sides by short vertical lines, equally spaced, representing 10-mil intervals. The space between each two lines is subdivided by a dot, forming 5-mil intervals. Rotation of the elevating cam raises or lowers the reticle within the sight,

M558655

thereby changing the effective elevation. The range dial on the elevating cam is graduated in yards from 0 to 3,000 and in mils from 0 to 61. The yard graduations conform to a muzzle velocity of 2,700 feet per second and to the ballistic data published in FT 0.50-AA-E-4. The mil graduations may be used with ammunition of any muzzle velocity and appropriate firing tables. A clamping screw is provided to lock the range dial at the operating setting. The telescopic sight has a deflection movement of 100 mils, controlled by the deflection knob and indicated on the deflection micrometer. A detent and ratchet operating within the deflection knob produce a click at each 1-mil change in deflection as the knob is rotated.

b. Operation.—To move the shots to the right, rotate the deflection knob in the direction indicated by the arrow on the index marked R until the required number of mils on that part of the micrometer scale marked R registers opposite the index pointer. This operation will rotate the body carrying the optical system to the left and therefore will move the post on the reticle to the left of the aiming point. When the gun is traversed to bring the post on the reticle back on the aiming point, placement of the shots will have moved the required number of mils (registered on the micrometer) to the right. Moving the shots to the left is accomplished in the same manner except that the part of the micrometer scale marked L is used.

3. Inspection.—Inspection is for the purpose of determining the condition of the sight, whether repairs or adjustments are required, and the remedies necessary to insure serviceability and proper functioning. The listing below will serve as a general guide for inspection. Refer to assembled and sectioned views of the sight for location of parts.

Parts to be inspected

Points to be observed

- | | |
|-------------------------------------|---|
| <i>a. Exposed mechanical parts.</i> | <i>a. Observe general appearance, functioning of range dial cam clamping screw, and any bent or missing parts. Scale and micrometer graduations and index lines should be clear and legible. Eyeshield should be in good condition.</i> |
| <i>b. Deflection mechanism.</i> | <i>b. Operate deflection worm knob, A45190, through complete range of motion (somewhat less than one complete turn). A definite click should be felt at each 1-mil interval. A stop should be felt at or beyond the scale limits.</i> |

*Parts to be inspected**Points to be observed*

c. Body bracket shoe.

c. Body bracket shoe should be firmly mounted on body bracket. Locating surfaces should be smooth, clean, and free from any imperfections which would impair the accuracy of the sight in its normal mounting.

d. Optical system.

d. The telescope reticle should appear in sharp focus of the eyepiece and should be free from parallax. Image should be sharp and clear. Use collimating telescope supplied in optical repair kit to check focus and to check cleanliness of internal optical parts. Dirt on optical surfaces can be seen by bringing successive surfaces into focus of the collimating telescope. Internal cleaning or realinement of optical elements, when necessary, is to be performed at an arsenal or base shop.

e. Range mechanism.

e. Note reticle motion through eyepiece while rotating range dial cam. There should be no evidence of sticking or binding. Range dial cam should operate smoothly without looseness or undue friction.

f. Alinement.

f. The telescopic sight is in adjustment when the line of sight through the telescope is parallel to the axis of the bore of the gun with the range dial and the deflection micrometer set at zero. The method of inspection will depend on the facilities available. Errors due to damage in handling or derangement of optical parts are usually large and can be checked by approximate methods.

4. Maintenance and repair.—*a. Tools.*—An optical repair kit containing the necessary tools and materials for use with these sights is furnished to ordnance maintenance companies. Every item in the kit is designated by a number equivalent to the compartment number in the kit tool chest. A complete list of the items comprising the kit is contained in a blueprint which is fastened in the cover of the chest. The collimating telescope, No. 90, which is furnished with the kit is an ordinary nonerecting type. It is adjusted for parallax by the usual means of focusing the eyepiece on the cross wires and then removing parallax by focusing the objective, temporarily loosening the drawtube clamping screw in the side of the tele-

scope for the purpose. The magnifying power of the collimating telescope is 9.78X; the field of view is 4°20'.

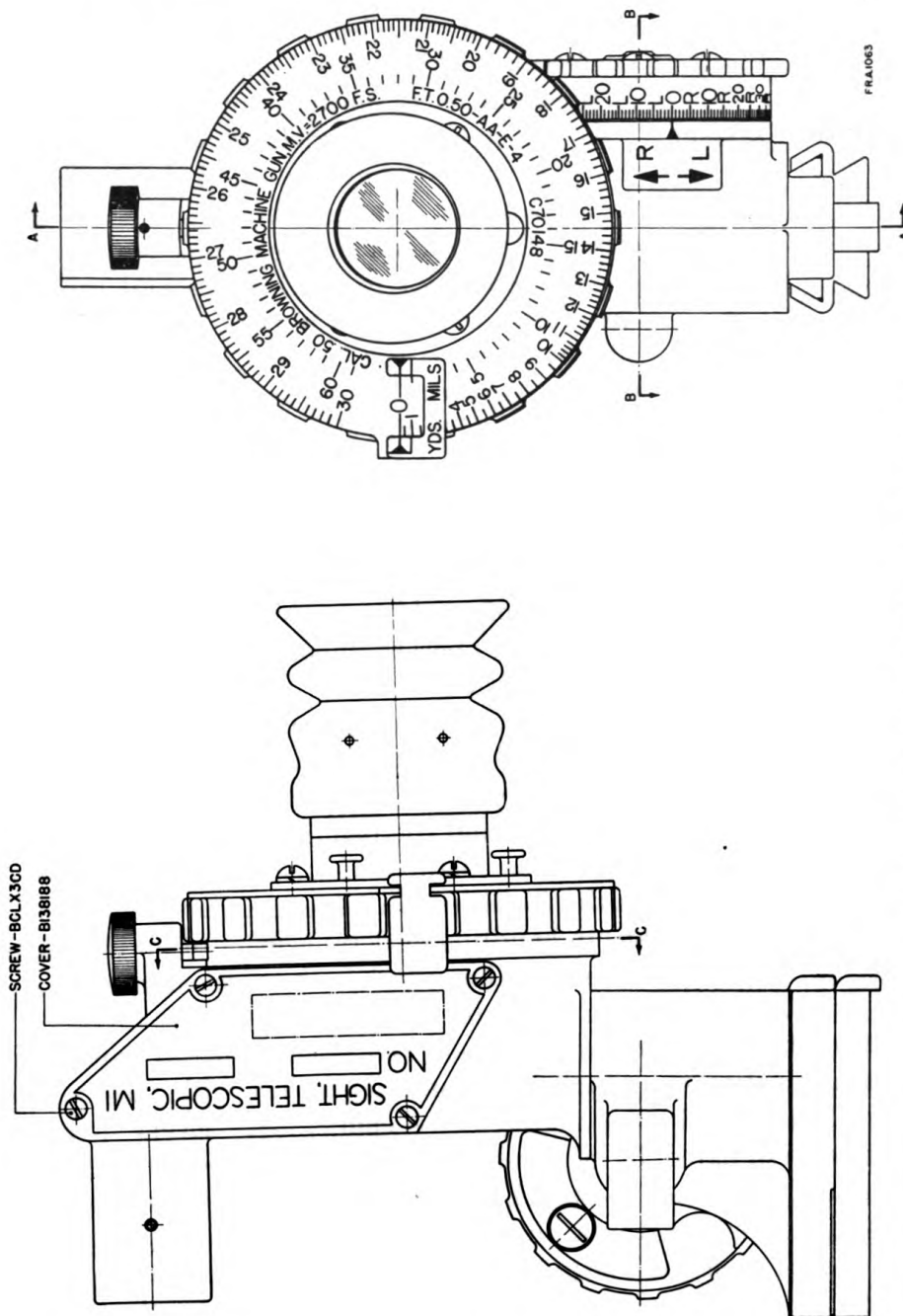
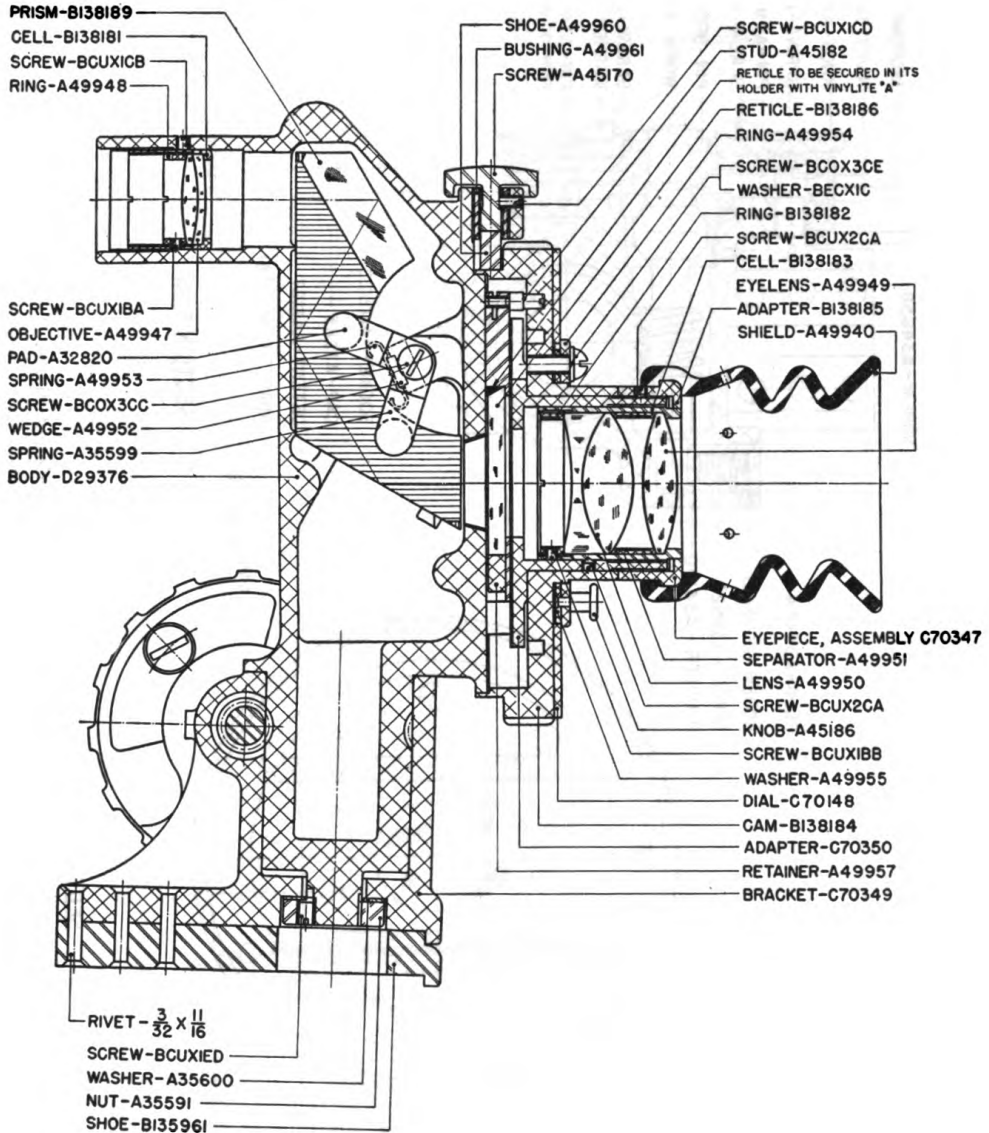

FIGURE 1.—Telescopic sight M1—*assembled views.*

b. Disassembly and assembly.—(1) Deflection mechanism.—(a) Remove deflection worm knob, A45190, and micrometer, B135962.

Drive out taper pin, BFCX1B, which secures micrometer adapter, B136381, and remove adapter with spring and detent. With these parts removed, ratchet and associated parts are exposed for examination, cleaning, or replacement.



SECTION A-A

FRA1064

FIGURE 2.—Telescopic sight M1—sectioned view.

(b) Remove deflection worm plunger plug, A34654, and deflection worm ball cap, A32115, each secured by headless locking screws, BCUX1CB and BCUX2CB. Loosen headless locking screw,

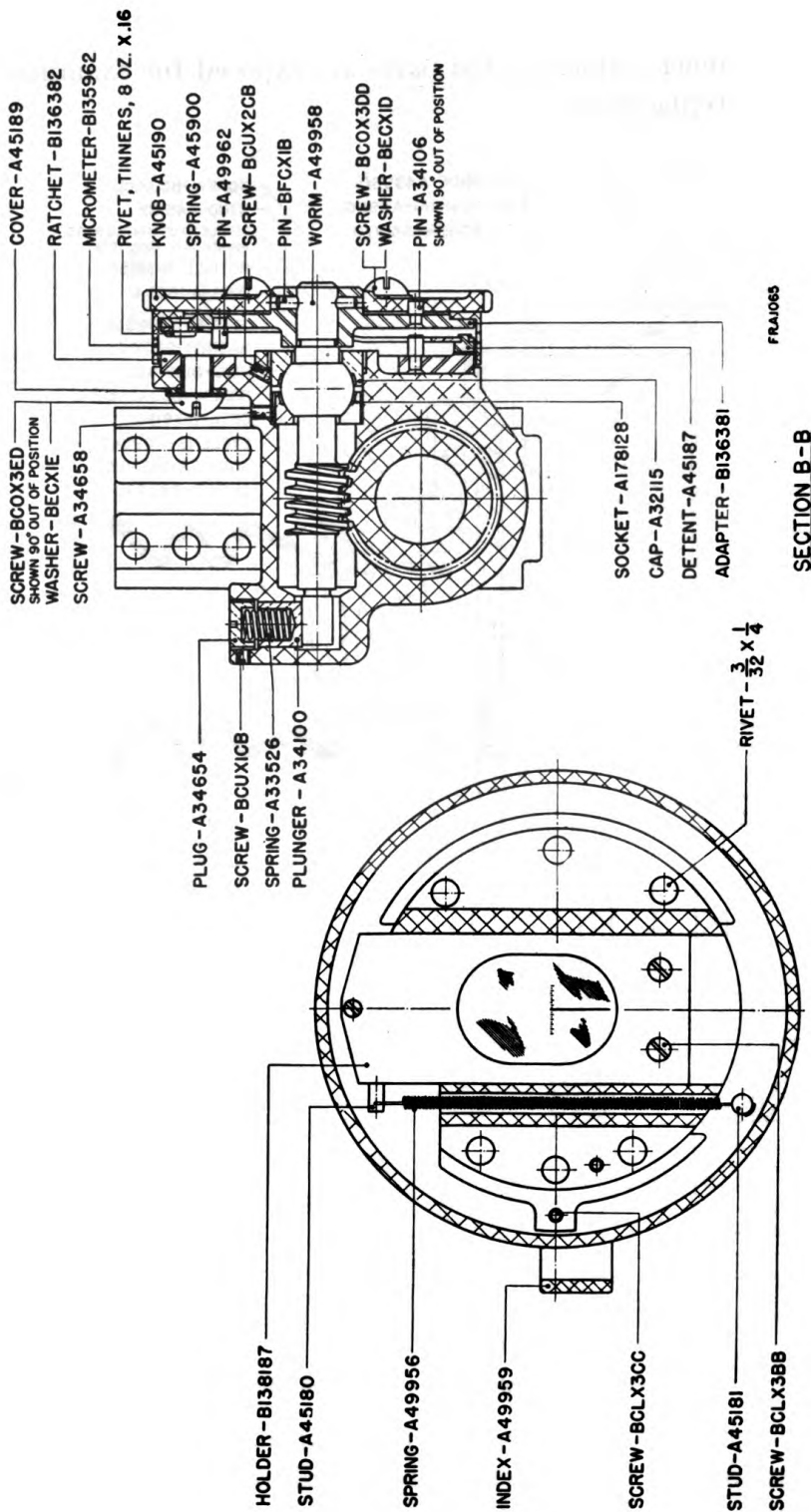

FRA1065

SECTION B-B

SECTION C-C

FIGURE 3.—Telescopic sight M1—sectioned views.

A34658, which secures ball socket, A178128. Remove deflection worm with ball socket attached.

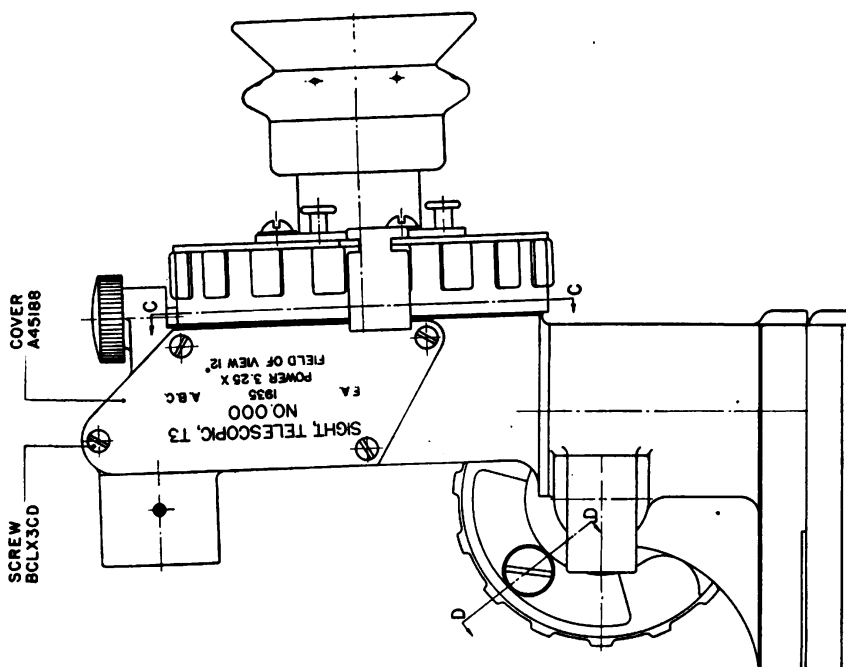
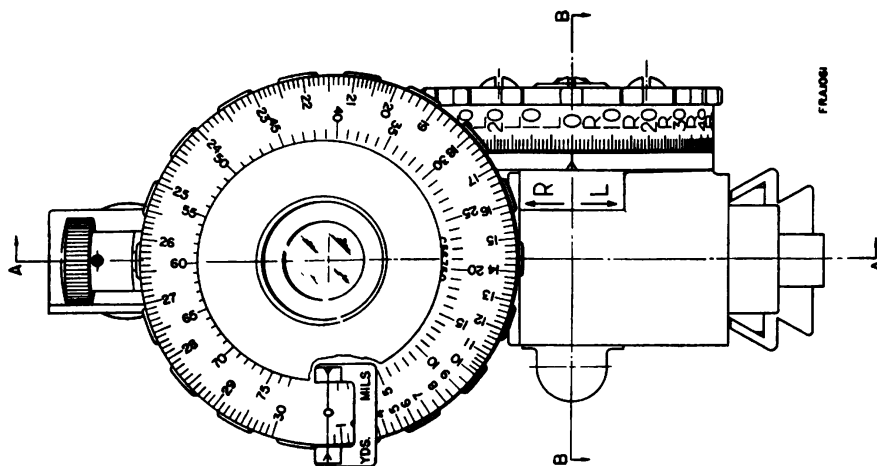

FIGURE 4.—Telescopic sight T3—-assembled views.

(c) Further disassembly involving removal of body from body bracket may be performed for cleaning purpose if required. Body is

retained by round nut, A35591, under opening in body bracket shoe, B135961.

(d) Clean and lubricate parts before reassembly. Reassemble in reverse order of disassembly. Adjust deflection worm ball cap, A32115, to a snug fit on ball with no binding.

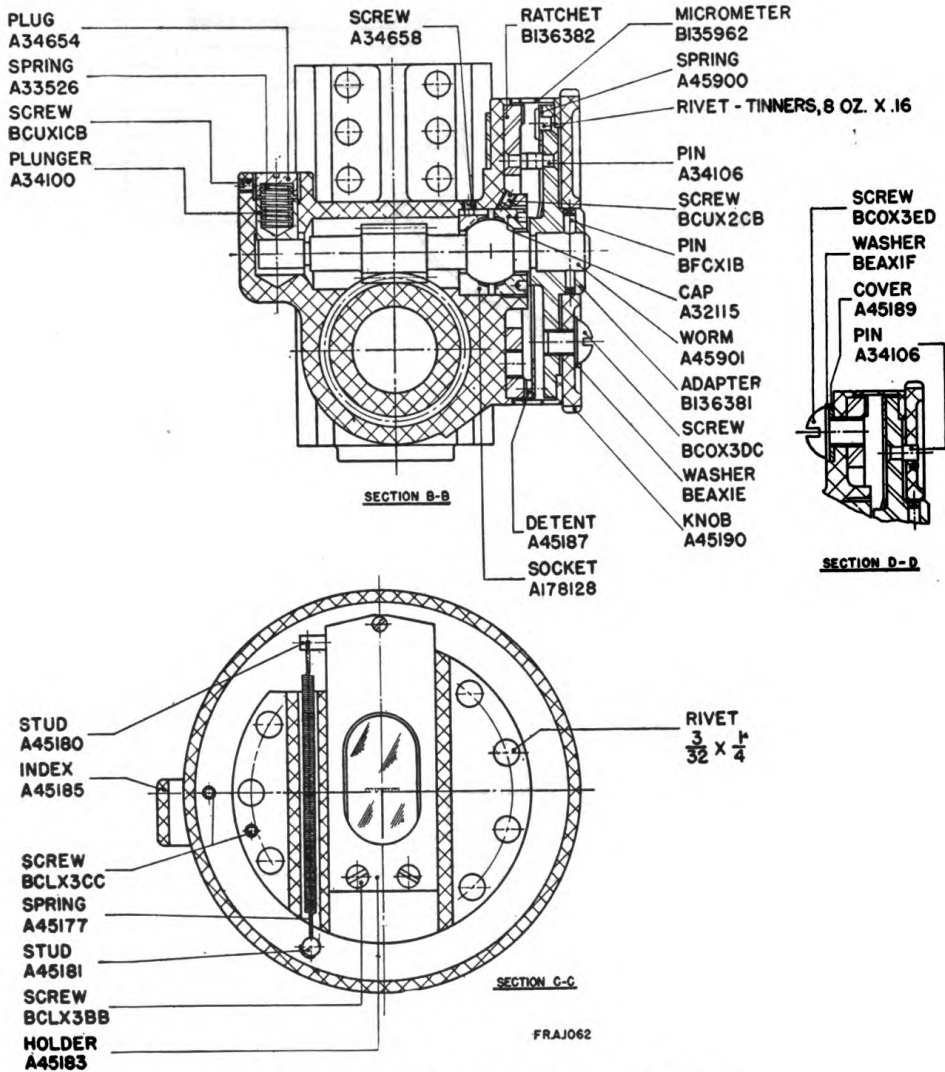

FIGURE 5.—Telescopic sight T3—sectioned views.

(2) *Range mechanism.*—(a) Disassembly and assembly operations are limited to those which do not affect the optical alinement of the sight. Repairs involving realinement or replacement of optical elements are to be performed at an arsenal or base shop.

(b) To remove range dial cam, B138184 (M1) or B135959 (T3), remove eyeshield, A49940, and unscrew eyeshield adapter, B138185

(M1) or A35581 (T3). Eyeshield adapter is secured by a headless locking screw under edge of eyeshield. Remove range dial index. Turn range dial cam to bring reticle to lowest position to avoid snapping of reticle retainer against stop when reticle retainer stud is

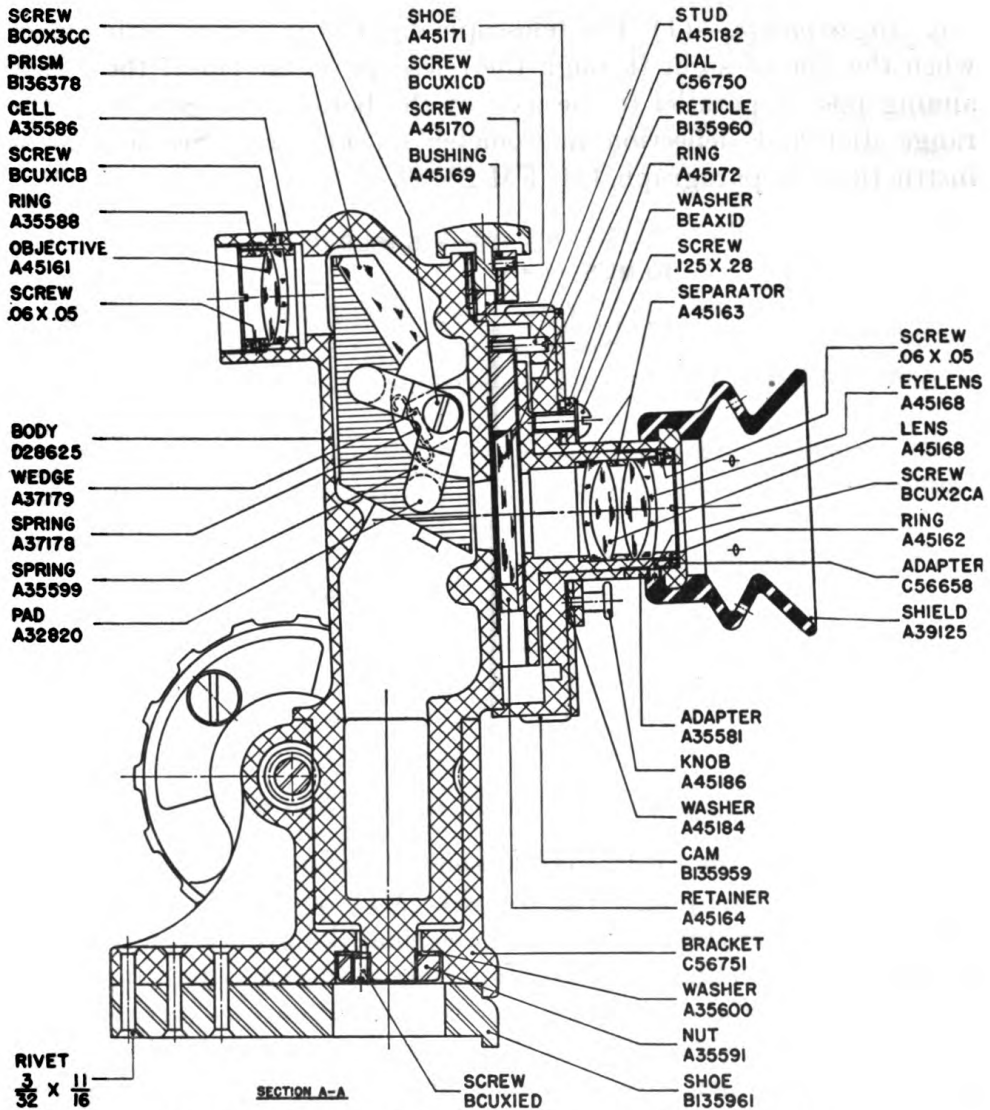

FIGURE 5.—Telescopic sight T3—sectioned views—Continued.

subsequently disengaged. Carefully draw range dial cam rearward until free.

(c) Additional minor disassembly and assembly of range dial cam parts may be performed if required. Accessible parts should be thoroughly cleaned. Reticle retainer guides and extension spring *must not be lubricated*.

(d) Reassembly is performed in reverse order of disassembly. When replacing eyeshield adapter, adjust to a snug fit on range dial cam, so that range dial cam operates smoothly and without undue friction. Check adjustment of range dial and readjust if necessary (c below).

c. *Adjustments.*—(1) The telescopic sight is in correct adjustment when the line of sight through the telescope at the tip of the reticle aiming post is parallel to the axis of the bore of the gun, with the range dial and deflection micrometer set at zero. See alinement instructions in paragraph 114, FM 23-60.

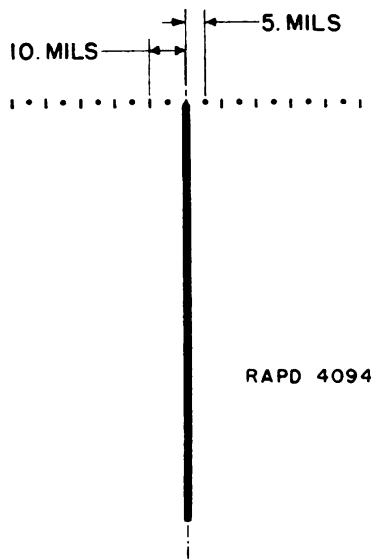

FIGURE 6.—Reticle pattern, telescopic sight M1.

(2) To adjust the range dial, loosen the three screws which secure the range dial clamping ring, A49954 (M1) or A45172 (T3). Pull out the clamping ring by means of the small knobs thereon until the toothed washer under the clamping ring disengages the range dial. Turn the range dial cam to bring the reticle into correct vertical alinement ((1) above) and lock in this position. Set the range dial to indicate zero, reengage the clamping ring toothed washer, and tighten the three screws which secure the clamping ring.

(3) To adjust the deflection micrometer, turn the deflection knob to bring the reticle into correct lateral alinement ((1) above). Loosen the three screws on the deflection knob and, while holding the knob, slip the deflection micrometer to the zero reading. Tighten the screws, being careful not to disturb the adjustment.

(4) If a large adjustment of the deflection micrometer has been made, it may be found that the deflection knob engages its stop before

the scale limit is reached. In this case, the following additional adjustment is required: Loosen the screw, BCOX3ED, on ratchet adjusting hole cover, A45189, and shift cover and screw until the stop engages at a point which permits full movement between scale limits. Tighten the screw at this setting.

d. Lubrication.—(1) The telescopic sight is adequately lubricated by the manufacturer and thereafter should require lubrication only at long intervals, and then only by trained ordnance personnel.

(2) Moving parts, except reticle parts, should be lubricated with grease, special, low temperature. Reticle parts should not be lubricated.

(3) For cleaning parts prior to lubrication, use dry-cleaning solvent.

5. Care and preservation.—*a. Care in handling.*—(1) Extreme care should be exercised in handling the telescopic sight and in mounting it on the gun so as not to drop it or bump any part of the range or deflection mechanism.

(2) When removed from the gun or whenever transported from one position to another, the telescopic sight should be kept in the carrying case provided for it.

(3) Do not force deflection knob or range dial cam beyond the limits indicated by the stops.

b. Cleaning of optical parts.—(1) Do not touch or attempt to clean the optical surfaces with the fingers or an oily cloth. A clean, dry camel's-hair brush or a tuft of tissue paper should be used to remove particles of dust and grit from the lens surfaces.

(2) To remove oil or grease from the lenses, apply alcohol sparingly with paper, tissue, or camel's-hair brush and wipe off carefully with paper, tissue. In the absence of alcohol, moisten the lens surface by breathing heavily on it and wipe off as directed above.

c. Cleaning of mechanical parts.—(1) Keep the sight clean and free of dust and grit which might work into the internal mechanism and optical system.

(2) Wipe the locating surfaces of the shoe before inserting the sight into its mount on the gun.

APPENDIX

LIST OF REFERENCES

1. **Standard Nomenclature Lists.**

- Telescopic sight M1..... SNL F-195
- Optical repair kit for Field Artillery..... SNL F-21
- Current Standard Nomenclature Lists are as tabulated here. An up-to-date list of SNL's is maintained as the "Ordnance Publications for Supply Index"..... OPSI

2. **Technical Manuals.**

- Telescopic sight M1..... TM 9-2581
- Cleaning and preserving materials..... TM 9-850
(now published as TR 1395-A)
- Matériel inspection and repair..... TM 9-1100

3. **Field Manual.**

- Browning machine gun, caliber .50, HB, M2, ground..... FM 23-60

[A. G. 062.11 (8-13-40).]

BY ORDER OF THE SECRETARY OF WAR:

G. C. MARSHALL,
Chief of Staff.

OFFICIAL:

E. S. ADAMS,
Major General,
The Adjutant General.

DISTRIBUTION:

R and H 2, 4, 7, 17 (2); Bn 9 (2); IC 9 (2).
(For explanation of symbols see FM 21-6.)

